

# TCA

## IMPORTANT

Read instructions carefully before installing, operating or repairing this tool. Keep these instructions in a safe and accessible place. Examine for damage when first opened. If damaged, return, with all packaging, to seller within 7 days.

Model: HD26TC05 (-BL, -BK, -RD)

## ATTENTION, SAFETY FIRST!

### Some Injury Prevention Information:

- \* Do not use this unit for storage, or repair it, unless it is secured and will not move.
- \* Work in a safe, clean, well lit, organized and adequately equipped area.
- \* Select the correct accessories of the correct size and
- \* Wear ANSI approved goggles.
- \* Normal use of this product is likely to expose the user to dust and/or microscopic particles containing chemicals known to the State of California to cause cancer, birth defects or other reproductive harm. Always wear appropriate safety equipment and clothing when using this product.
- \* Study, understand and follow all instructions provided with this product.

## PRODUCT TYPE:

**HD SERIES, 26", 4 DRAWER,  
TOOL STORAGE CHEST**

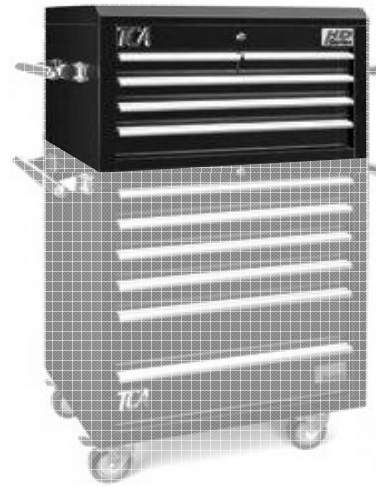

## INFORMATION ON PRODUCT

**Cabinet is double wall, heavy steel construction (1.0 and 1.5 mil).**

Overall Dim.	w	d	h
	26.5"	18.5"	17"
	67cm	47cm	43cm

- \* **4 drawers**, with skid proof liners.
- \* **Ball bearing sliders** (110 lb) on all drawers.
- \* **Double sliders** on drawers of 4"h & over.
- \* **Handles included** for both ends of cabinet.
- \* **Keyed lock system.** Roller cabinet has two extra keyed-alike locks included.
- \* **Industrial gloss powder coat paint.**
- \* **Net Weight:** 92 lb (42 kg).
- \*

## MAINTENANCE INSTRUCTIONS:

### **Tightness of Parts:**

Regularly check whether all connection parts are fastened securely. Follow this procedure daily before beginning work.

### **Lubrication:**

Depending on conditions, regularly use an appropriate lubricant on drawer sliders and the wheel swivels.

### **Ordering Service parts:**

For further operational and handling information or for replacement of parts and components, contact the sales agent from where you purchased the tool, or the service division of our company. When ordering parts or components, give Item #, G #, and quantities.

## 3 YEAR LIMITED WARRANTY

- \* The manufacturer warrants this product to the original user against defective material or workmanship for a period of three years from the purchase date.
- \* The manufacturer reserves the right to determine whether the part or parts failed because of defective material, workmanship or other causes. Also, failures caused by accidents, alterations or misuse are not covered by this warranty.
- \* The manufacturer, at his discretion, will repair or replace products covered under this warranty free of charge. Repairs or replacements of products covered under this warranty are warranted from the original warranty date.
- \* The manufacturer or his authorised service representative must perform all warranty repairs. Any repair warranty is limited to the original user and may not be transferred to subsequent users.
- \* This warranty is in lieu of all other warranties, expressed or implied, including warranties of merchantability and the fitness for a particular purpose. Some jurisdictions do not allow the exclusion or limitations of incidental or consequential damages, so the above limitations may not apply to you.

# TCA

### IMPORTANT

Read instructions carefully before installing, operating or repairing this tool. Keep these instructions in a safe and accessible place. Examine for damage when first opened. If damaged, return, with all packaging, to seller within 7 days.

Model: HD26TC05 (-BL, -BK, -RD)

# TCA

### IMPORTANT

Read instructions carefully before installing, operating or repairing this tool. Keep these instructions in a safe and accessible place. Examine for damage when first opened. If damaged, return, with all packaging, to seller within 7 days.

Model: HD26TC05 (-BL, -BK, -RD)

### PRODUCT TYPE:

HD SERIES, 26", 4 DRAWER, TOOL STORAGE CHEST

### PRODUCT TYPE:

HD SERIES, 26", 5 DRAWER, TOOL STORAGE CHEST

\*Install the handles first to make it easier to move the tool chest.\*

#### To Install Handle

1. Position handle over the 4 holes at the side of the cabinet.
2. Attach handle with hex bolts provided. Tighten securely.

#### To Remove Drawers

1. Pull drawer out so it is fully extended.
2. Push down the black lever on the left side of the drawer. Push up the black lever on the right side of the drawer as shown in Figure 1 below.
3. While holding levers, pull the drawer outward until it is released from the drawer slide.

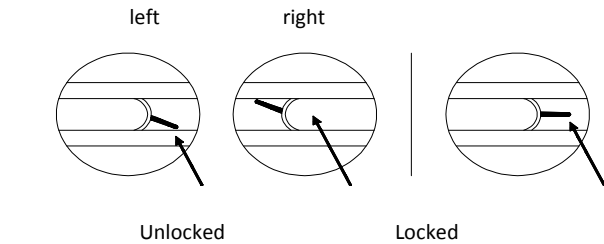
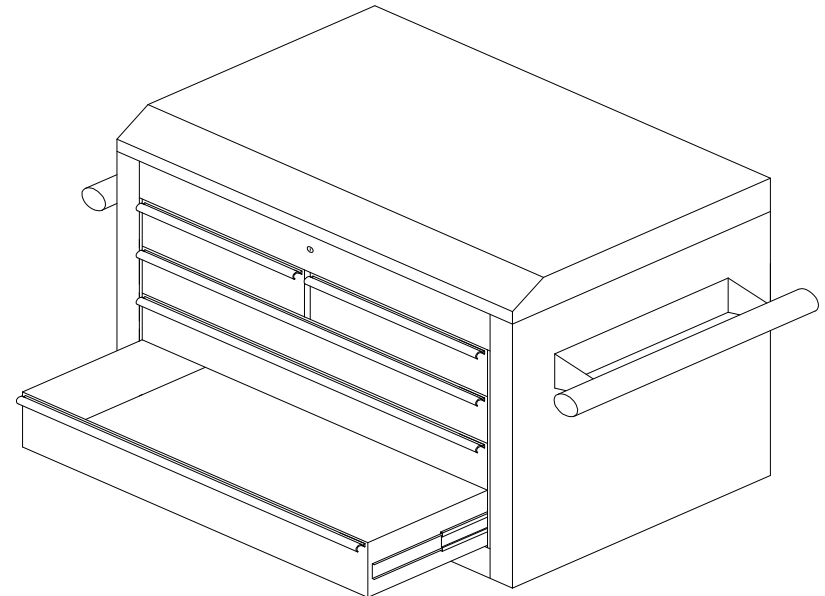

Fig. 1 Removing Drawers



#### To Replace Drawers

1. Slide drawer sliders onto cabinet sliders.
2. Push the slider until half way on drawer.
3. Push the drawer in, in stages, until fully

Handles are not to be used to lift any cabinet.

Web Site: [www.tcatoolstorage.com](http://www.tcatoolstorage.com)